

Fact Sheet for a Nominal 900 Barrel Per Day Gasoline-To-Go[®] Plant

Gasoline-To-Go[®] is an add-on option for MeOH-To-Go[®] plants that allows production of 88 Octane Gasoline ((R+M)/2) plus LPG blend instead of Methanol, or production of Gasoline and LPG blend in combination with Methanol. The Gasoline produced by Gasoline-To-Go[®] is a high quality, low sulfur, low Benzene motor fuel that meets typical gasoline specifications and only requires the addition of an additive package. With an additive package, the fuel can be used directly in gasoline fueled vehicles, with no other treatment or purification. The LPG blend produced by Gasoline-To-Go[®] is a mixture of propane and butane, which can be burned as a fuel or sold into the mixed LPG market.

Gasoline-To-Go[®] incorporates well-proven methanol-to-gasoline technology with Modular Plant Solutions' small-scale modularization technology, reducing field construction risk and making the plant moveable if needed. The Gasoline-To-Go[®] plant combined with MeOH-To-Go[®] includes all chemical processing equipment modules required to produce high Octane, low sulfur gasoline. The plant includes components such as heat exchanger modules, reactor modules, distillation modules, compressor and pump modules, as well as storage tanks and truck loading facilities for gasoline and LPG. The Gasoline-To-Go[®] plant is designed for remote operations in field locations anywhere in the world. These plants enable users to convert flared gas or stranded gas into a liquid motor fuel that can be used locally or can be transported by truck to nearby markets. The combination of MeOH-To-Go[®] and Gasoline-To-Go[®] is designed to be a complete, stand-alone facility, so it includes all utilities and infrastructure required for production of gasoline and LPG from natural gas.

Gasoline-To-Go[®] add-on to MeOH-To-Go[®] provides for:

- Production of approximately 900 Bbl/day of gasoline plus 190 Bbl/day of LPG blend
- Gasoline production can vary up or down slightly from the nominal 900 Bbl/day depending on the composition of the feedstock
- MeOH-To-Go[®] and Gasoline-To-Go[®] can be designed as a flexible unit to produce both methanol and gasoline
- Variation of production – it can be approximately 300 MT/day of Methanol with zero gasoline production, or 150 MT/day of Methanol and 450 Bbl/day of gasoline plus 95 Bbl/day of LPG, or zero production of Methanol and 900 Bbl/day of gasoline and 190 Bbl/day of LPG

The Gasoline-To-Go® Diagram of Process Components

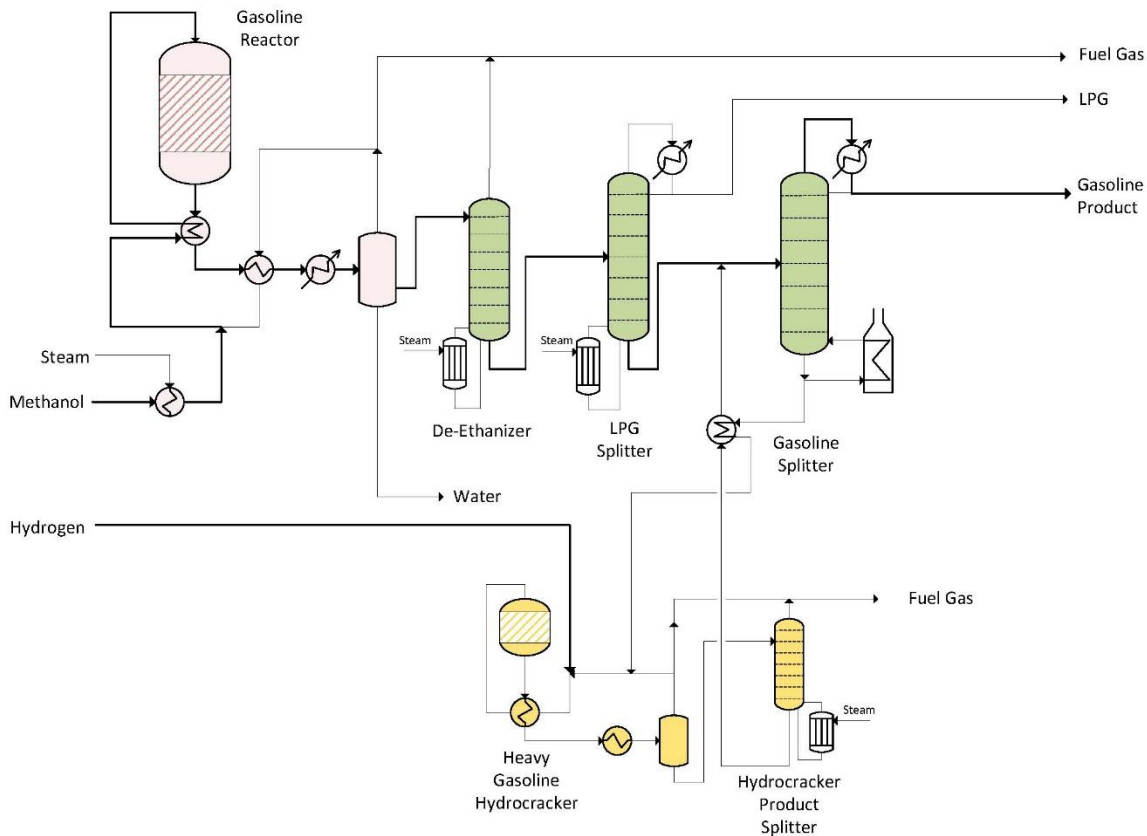

Production Details

900 Bbl/day of 88 Octane gasoline = 37,800 gal/day
 190 Bbl/day of mixed Propane-Butane = 7,980 gal/day

Inputs Needed (for MeOH-To-Go® and Gasoline-To-Go® combined)

Natural Gas Requirements

Pressure 210 psig
 Quantity 11,067 mm Btu/day
 Max N₂ * 20 %
 Max CO₂ ** 25 %

Electricity Requirements***

Voltage 4,160 V
 Load 9.4 MW

Raw Water Requirements

Pressure 60 psig
 Quantity 45 gpm

Site Requirements

Area 5 Acres
 Road Access for Product and Construction

* Higher N₂ reduces capacity.

** Higher CO₂ maintains capacity at lower energy costs.

*** Electricity can be self-generated if necessary, but additional natural gas will be required. Mixed LPG product can be used to provide about 40% of fuel required for electricity generation.

Cost to Purchase

The purchase price for Gasoline-To-Go® varies and is dependent upon location for various climate control needs, material pricing at time of purchase, and other variables to be confirmed. Please contact MPS to discuss your project and plant needs for a firm plant cost.

Gasoline-To-Go® was developed by Modular Plant Solutions, a global engineering firm specializing in process modularization and project implementation. More information can be found at modularplantsolutions.com.

Phone: 281-968-6300 | Email: info@modularplantsolutions.com
www.modularplantsolutions.com | linkedin.com/company/modular-plant-solutions